

## The Beginning: A look at MØD

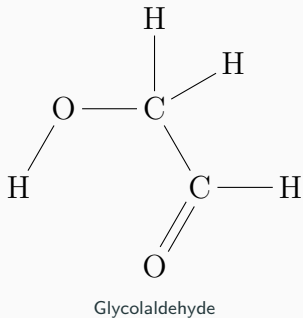

# The Beginning: A look at MØD

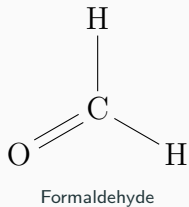
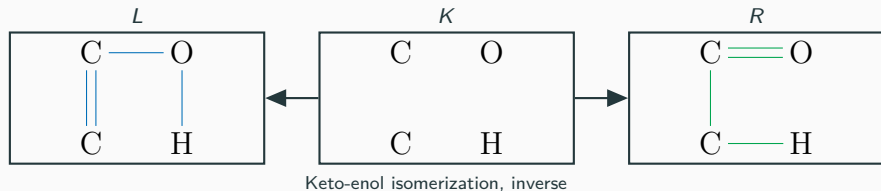
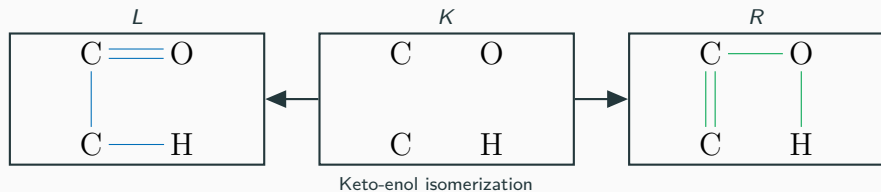

# The Beginning: A look at MØD

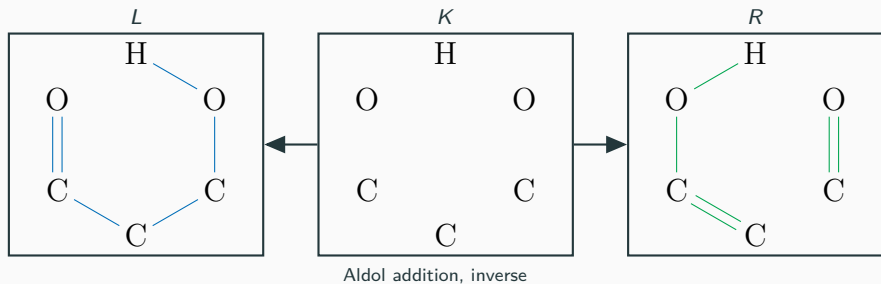
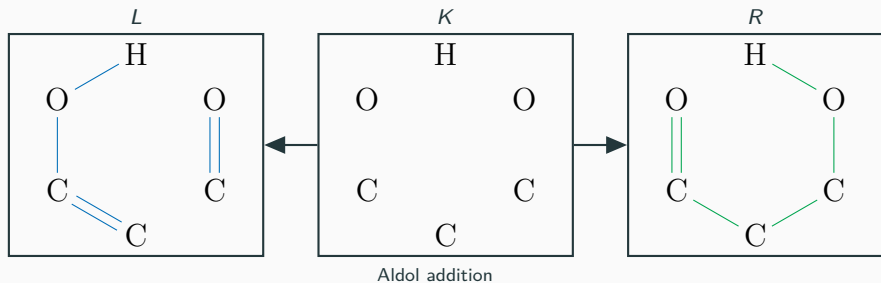

# The Beginning: A look at MØD

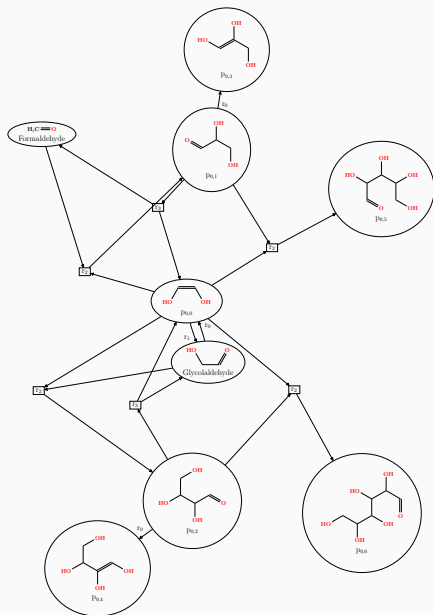

# Tracking Atoms Through Reactions

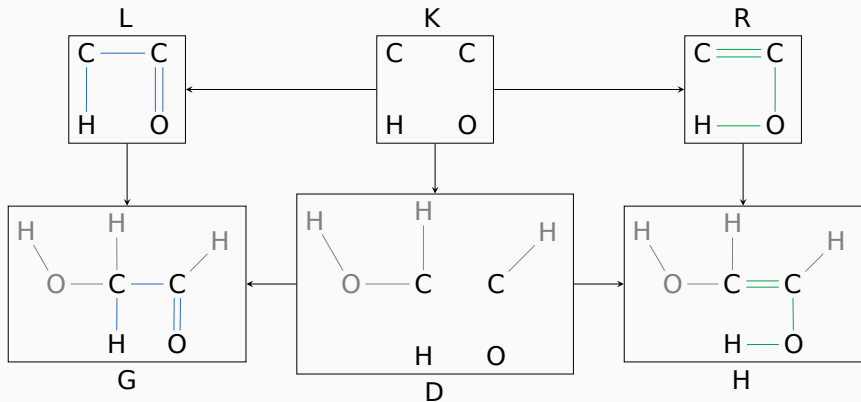

# The Characteristic Semigroup of Reaction Networks

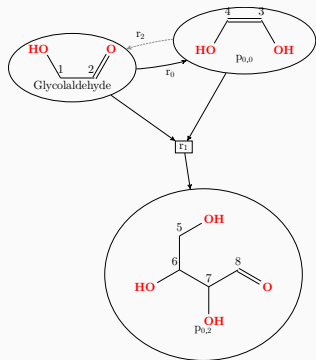

Marc Hellmuth, Daniel Merkle, and **Nikolai Nøjgaard**, *Atom tracking using cayley graphs*, 16th International Symposium on Bioinformatics Research and Applications (accepted) (2020)

# The Characteristic Semigroup of Reaction Networks

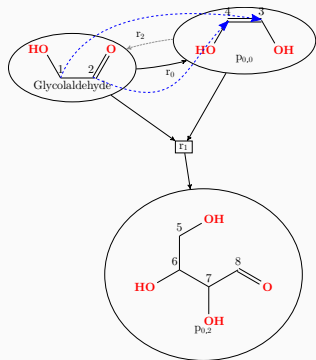

$$s_1 = [3, 4, 3, 4, 5, 6, 7, 8]$$

Marc Hellmuth, Daniel Merkle, and Nikolai Nøjgaard, *Atom tracking using cayley graphs*, 16th International Symposium on Bioinformatics Research and Applications (accepted) (2020)

# The Characteristic Semigroup of Reaction Networks

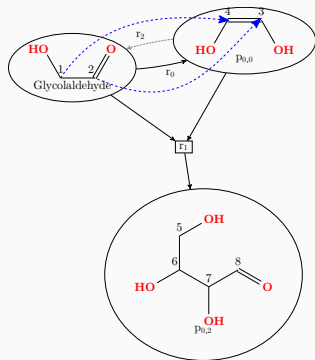

$$s_1 = [3, 4, 3, 4, 5, 6, 7, 8]$$

$$s_2 = [4, 3, 3, 4, 5, 6, 7, 8]$$

Marc Hellmuth, Daniel Merkle, and Nikolai Nøjgaard, *Atom tracking using cayley graphs*, 16th International Symposium on Bioinformatics Research and Applications (accepted) (2020)



# The Characteristic Semigroup of Reaction Networks

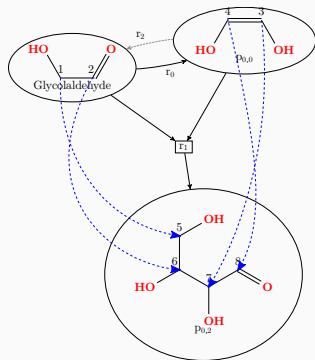

$$s_1 = [3, 4, 3, 4, 5, 6, 7, 8]$$

$$s_2 = [4, 3, 3, 4, 5, 6, 7, 8]$$

$$s_3 = [5, 6, 7, 8, 5, 6, 7, 8]$$

---

Marc Hellmuth, Daniel Merkle, and Nikolai Nøjgaard, *Atom tracking using cayley graphs*, 16th International Symposium on Bioinformatics Research and Applications (accepted) (2020)

# The Characteristic Semigroup of Reaction Networks

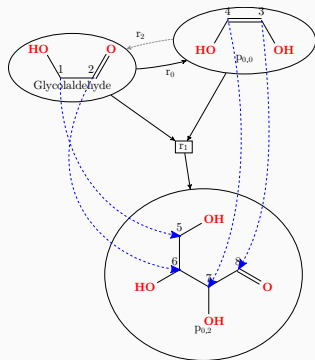

$$s_1 = [3, 4, 3, 4, 5, 6, 7, 8]$$

$$s_2 = [4, 3, 3, 4, 5, 6, 7, 8]$$

$$s_3 = [5, 6, 7, 8, 5, 6, 7, 8]$$

$$s_4 = [5, 6, 8, 7, 5, 6, 7, 8]$$

Marc Hellmuth, Daniel Merkle, and Nikolai Nøjgaard, *Atom tracking using cayley graphs*, 16th International Symposium on Bioinformatics Research and Applications (accepted) (2020)

# The Characteristic Semigroup of Reaction Networks

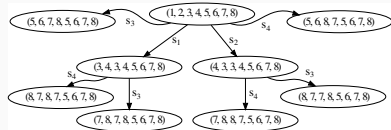
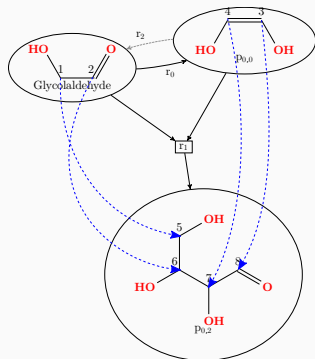

$$s_1 = [3, 4, 3, 4, 5, 6, 7, 8]$$

$$s_2 = [4, 3, 3, 4, 5, 6, 7, 8]$$

$$s_3 = [5, 6, 7, 8, 5, 6, 7, 8]$$

$$s_4 = [5, 6, 8, 7, 5, 6, 7, 8]$$

Marc Hellmuth, Daniel Merkle, and Nikolai Nøjgaard, *Atom tracking using cayley graphs*, 16th International Symposium on Bioinformatics Research and Applications (accepted) (2020)

# The Projected Cayley Graph

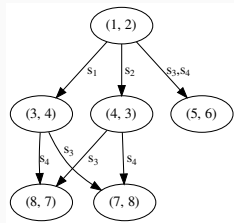
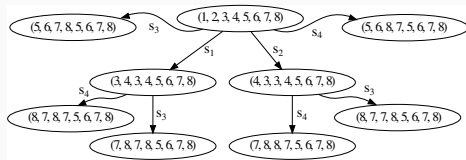

# Reversible Eventtraces

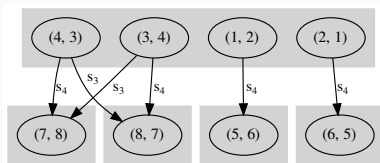
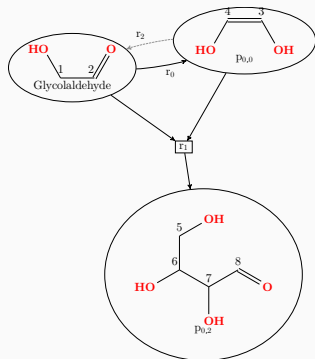

## Natural Subsystems

The natural subsystems of a characteristic semigroup is the set of equivalence classes induced by the  $\mathcal{R}$ -relation.

# The TCA Cycle

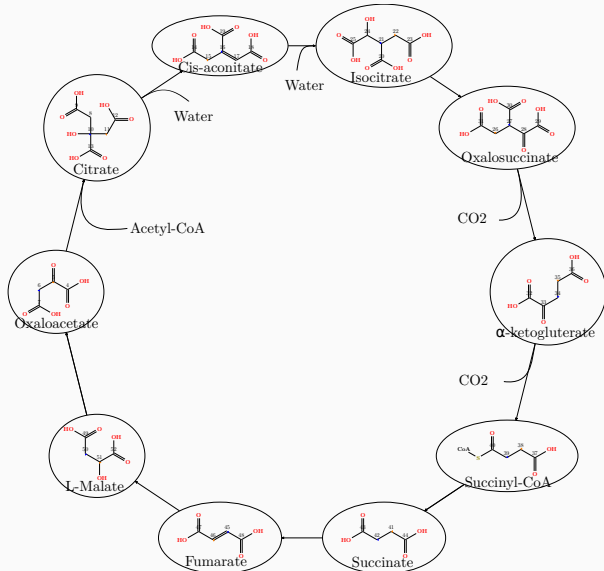

# Stereochemistry in Citrate

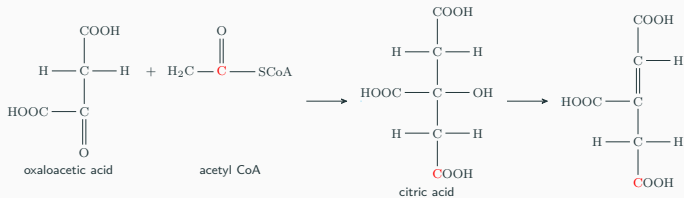

Correct Mechanism

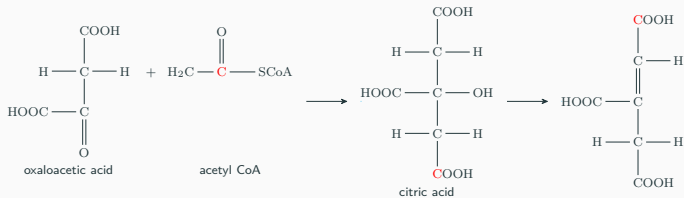

Wrong Mechanism

# Carbon Trajectories and Cayley Graphs

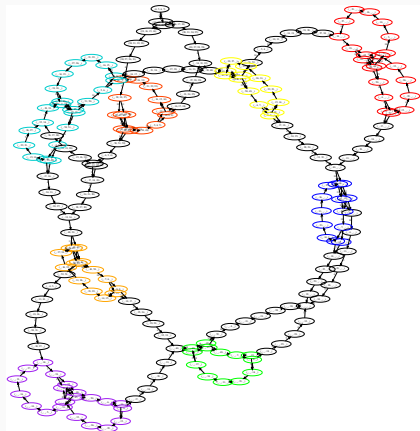
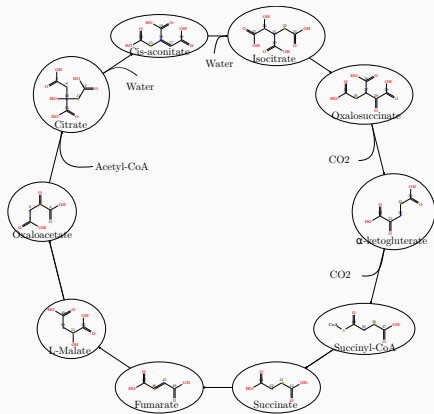
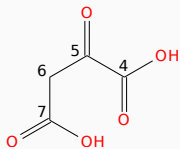



# Carbon Trajectories and Cayley Graphs

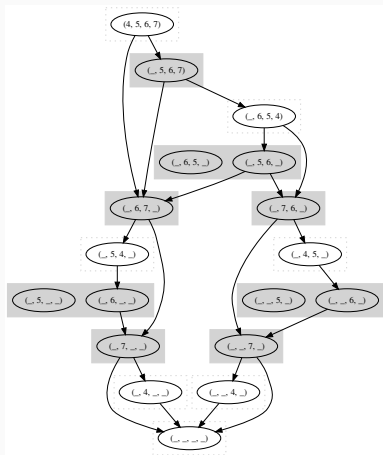
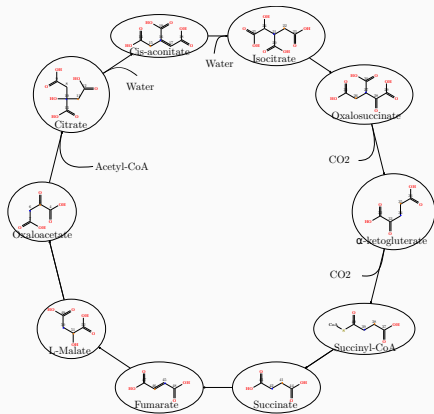
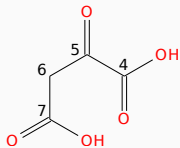

# Carbon Trajectories and Cayley Graphs

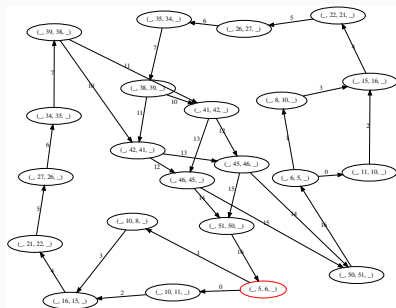
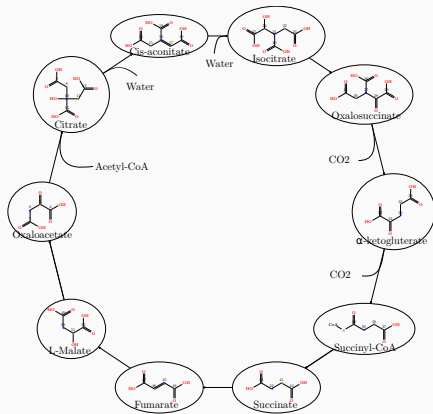
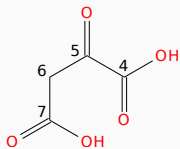

# Carbon Trajectories and Cayley Graphs

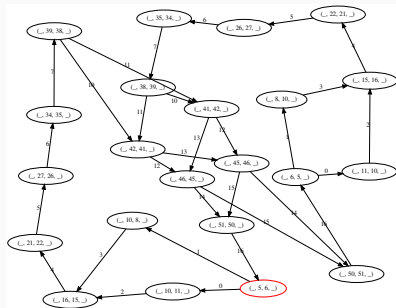
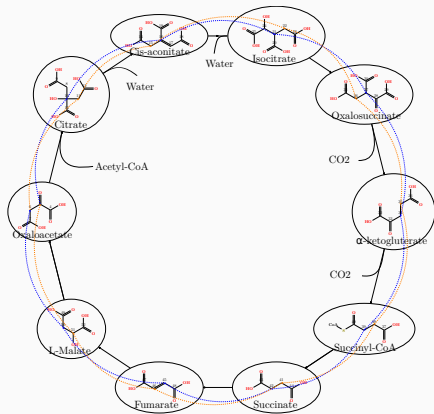
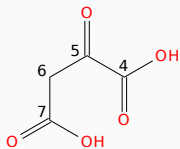

# Carbon Trajectories and Cayley Graphs

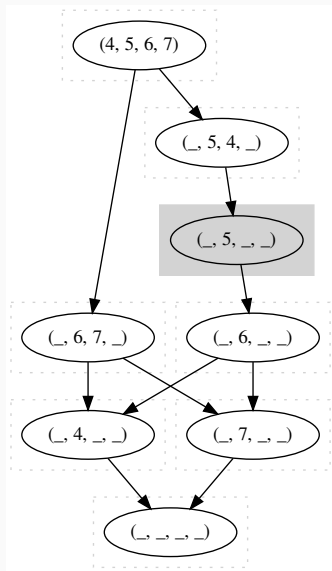
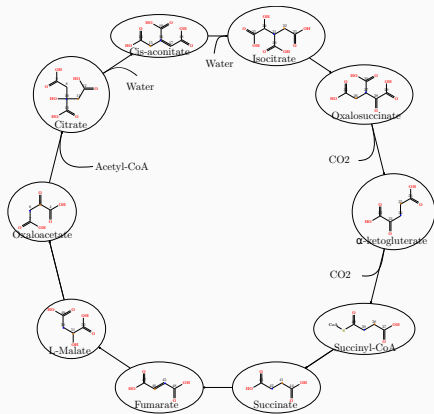
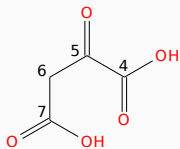

## Summary

- Any reaction network constructed from a graph grammar has a characteristic semigroup.

## Summary

- Any reaction network constructed from a graph grammar has a characteristic semigroup.
- Using it we can track the trajectories of select atoms in relation to each other.

## Summary

- Any reaction network constructed from a graph grammar has a characteristic semigroup.
- Using it we can track the trajectories of select atoms in relation to each other.
- Allows for relatively easy modifications to account for e.g. stereochemistry.